



## Medical Screw Compressor Enclosure With Air Treatment Center Package (MDRE and MTRE)\*

Rev. 09/09/13

### GENERAL

The Powerex Medical Screw Compressor Enclosure package shall include multiple oil-free rotary screw air compressors modules and associated equipment and an Air Treatment Center Package (shipped separately). System is in full compliance with NFPA 99 requirements for Category 1 “Life Support Equipment”. Each system is completely tested before shipment and includes:

- Multiple oil-free rotary screw air compressor modules and associated equipment

Air Treatment Center Package includes:

- Corrosion resistant air receiver
- Dual Desiccant air dryers
- Dual filtration system
- Carbon monoxide monitor
- Dew point monitor

System installation requirements:

1. Main power to each Compressor Module
2. Single phase 120V utility power to the Air Treatment Center control panel
3. For systems with a tank mounted separately, wiring of utility power to the tank auto drain from the Air Treatment Center control panel
4. Interconnecting plumbing connections between each compressor and tank/dryer skid

### OIL-FREE ROTARY SCREW AIR COMPRESSOR MODULE

The standard assembly includes:

- Patented super rotor screw elements with cooling jackets, flange mounted to gear box with integral oil sump
- Air (or water) cooled intercooler and aftercooler with corrosion resistant centrifugal moisture separators and automatic fail safe drains
- Air intake filter/silencer with replaceable element
- Discharge air check valve and safety relief valve
- Pressure lubrication system with an independent motor driven gear type oil pump, providing pre and post lubrication. Gear box/oil sump breather and spin on oil filter. Air (or water) cooled oil cooler.
- Integral base and frame for compressor and drive assembly
- Full sound attenuating enclosure with removable doors
- Load/unload capacity control valve with blow off valve and muffler
- ODP flange mounted main motor
- Electrical enclosure with Wye-Delta motor starter mounted and wired

- Allen Bradley PLC (programmable logic controller) microprocessor
- Touch screen operator interface

Each compressor shall include a discharge check valve, isolation valve, air or water cooled aftercooler, a moisture separator with automatic drain, and a high discharge temperature shut down switch. Isolation valve is shipped loose for field installation.

### MOTORS

Each compressor shall be direct driven by an ODP, NEMA construction motor. Motors are EISA compliant and premium efficient.

### COMPRESSOR CONTROL PANEL

Operation of the compressor and display of essential systems is accomplished with an Allen Bradley PLC and the touch screen display for each compressor. This Programmable Logic Controller and display can easily be programmed to meet varying operating requirements.

Description of Features:

- Compressor Status Indication
- Hour Meter
- Alarm Bell
- Pressure Indicators
- Temperature Indicators
- Service Requirement Indicators
- Pre-Alarm Indicators
- Remote Input Commands (Optional)
- Compressor Safety Shutdown Indications
- Remote Output Status
- Event alarm log
- Manual load/unload switch
- Connection to DCS (remote monitoring capabilities via customer computer system) (Optional)

NFPA Features:

- Non-fused disconnect switch on each unit
- Automatic lead/lag control
- Reserve in use alarm
- Auto restart after power failure
- Remote Inlet air adapter

The Air Treatment Center control panel provides power to the dryer skid, monitors, and tank auto drain. The touch screen control panel on each air compressor module has all the alarm contacts and operations for the compressor modules; the Air Treatment Center control panel has connections for the monitor alarms.

\*NOTE: MDRE stands for Medical Duplex Rotary Screw Enclosure with Air Treatment Center Package, MTRE stands for Medical Triplex Rotary Screw Enclosure with Air Treatment Center Package



## Medical Screw Compressor Enclosure With Air Treatment Center Package (MDRE and MTRE)\*

Rev. 09/09/13

### **OPTIONAL VFD CONTROL PANEL:**

Each compressor to be equipped with an integrated Allen Bradley VFD motor control to maximize energy efficiency of the compressor under partial load conditions.

### **AIR RECEIVER**

The system shall include an ASME air receiver rated for 200 PSI MAWP. 240 gallon tanks are skid mounted with the Air Treatment Center. 400 gallon and larger tanks are shipped loose and include the same accessories mentioned below. (Accessories may require field installation.) The tank shall be equipped with:

- Sight gauge
- A pressure gauge and a safety relief valve
- 3-valve bypass
- Zero air loss type automatic moisture drain (with manual drain valve back up)

The receiver shall be internally lined for corrosion resistance.

**NOTE:** Air receivers for use with water cooled compressor units include a liquid level switch for compressor shut off and local alarm.

### **AIR TREATMENT CENTER**

The medical dryer package is a skid mounted design consisting of the receiver tank (if 240 gal. or less; 400 gal. tanks are shipped loose), dual desiccant air dryers, dual desiccant air dryers, dual filtration system, CO and dew point monitors, a sample port and all bypass piping. All components are mounted and plumbed together with bypass valves in accordance with NFPA 99 for Medical Air Systems. Final safety relief valve also included. Piping to be brass, stainless, or type K copper, and cleaned for medical air use. Piping from the compressor outlet to the tank assembly is to be field furnished and installed. Compressed air from the tank assembly is routed to the Air Treatment Center by field provided and installed piping. (240 gal. tanks are factory piped to the dryers.)

### **DESICCANT AIR DRYERS**

The twin-tower, heatless desiccant air dryer shall yield a pressure dew point of -20 degrees F. The dryer shall be installed and plumbed on a common steel skid to the air receiver for systems with 240 gal. tanks. Dryer is on a separate skid for systems with 400 gal. tanks. The dryer design shall be of the automatic pressure swing, heatless, regenerative type and shall include a purge muffler for quiet operation.

The filtration system shall consist of 2 stages of filtration mounted and plumbed to the air dryer. The first stage of filtration shall include a .01 micron coalescing pre-filter with element change indicator and automatic condensate drain and

installed up-stream of the air dryer. The second stage shall include a 1 micron particulate filter with element change indicator and installed downstream of the air dryer. Activated carbon final filters are standard.

### **DEWPOINT MONITOR**

The system-integrated hygrometer shall be equipped with an LCD dewpoint display and high dewpoint alarm with dry contacts connected to main controls panel. The sensor shall include an auto calibration feature to ensure the accuracy of the dewpoint measurement.

### **CO MONITOR**

Carbon monoxide (CO) monitor is in an enclosure with LCD display of CO concentrations. The monitor shall continuously display the CO content of the discharge air and shall provide audible and visual high CO alarms. Dry contacts are provided for remote monitoring of the high CO alarm on the Air Treatment Center control panel.

**\*NOTE:** MDRE stands for Medical Duplex Rotary Screw Enclosure with Air Treatment Center Package, MTRE stands for Medical Triplex Rotary Screw Enclosure with Air Treatment Center Package



# Duplex Medical Screw Compressor Enclosure (Air Cooled) and Air Treatment Center Package

Rev. 9/9/13

| DIMENSIONS |        |        |         |        |         |        |        |
|------------|--------|--------|---------|--------|---------|--------|--------|
| MODEL      | DIM. A | DIM. B | DIM. B1 | DIM. C | DIM. C1 | DIM. D | Outlet |
| MDRE0406   | 104"   | 32"    | 67"     | 59"    | 95"     | 24"    | 1-1/2" |
| MDRE0507   | 57"    | 47"    | 70"     | 67"    | 63"     | 24"    | 2"     |
| MDRE0607   | 57"    | 47"    | 70"     | 67"    | 77"     | 24"    | 2"     |
| MDRE0757   | 57"    | 47"    | 70"     | 67"    | 77"     | 24"    | 2"     |
| MDRE1007   | 57"    | 47"    | 70"     | 67"    | 77"     | 24"    | 2"     |

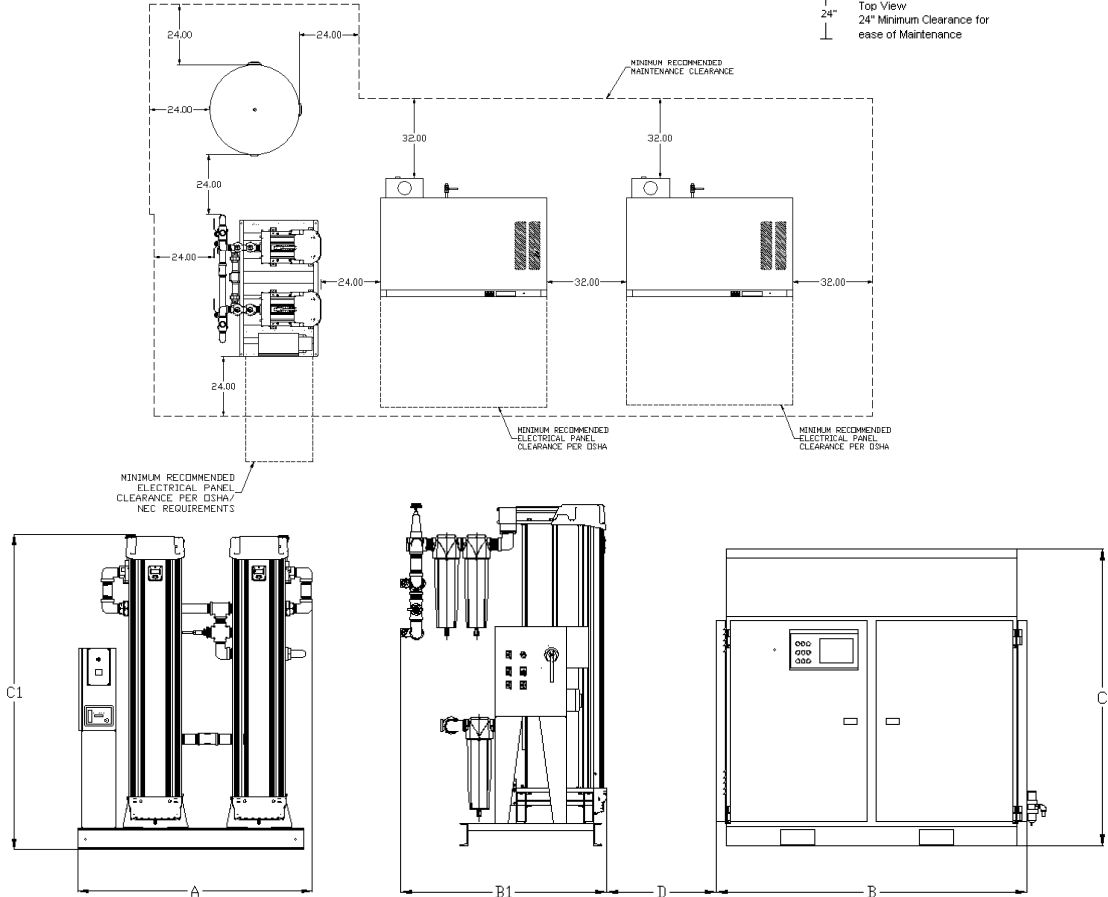
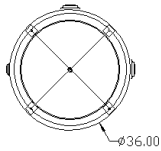
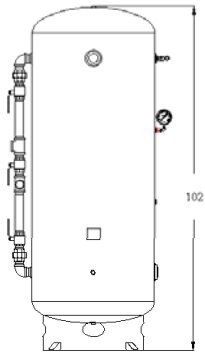
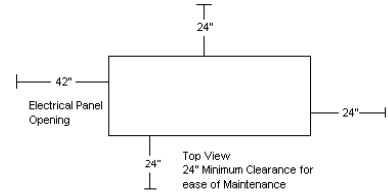

| Duplex Medical Screw Enclosed Air Compressors (Air Cooled) |     |                              |                  |                       |                          |                         |      |                            |                   |                          |
|--|-----|------------------------------|------------------|-----------------------|--------------------------|-------------------------|------|----------------------------|-------------------|--------------------------|
| with Air Treatment Center Package                          |     |                              |                  |                       |                          |                         |      |                            |                   |                          |
| MODEL  | HP  | SCFM @ 100 PSIG <sup>1</sup> | Tank Size (Gal.) | BTU/Min. <sup>3</sup> | dB(A) LEVEL <sup>2</sup> | RATED AMPS <sup>3</sup> |      | Compressor Unit Wt. (Lbs.) | Tank Wt. (Lbs.)** | Dryer Package Wt. (Lbs.) |
|  |     |                              |                  |                       |                          | 230V                    | 460V |                            |                   |                          |
| MDRE0406   | 40  | 165                          | 240              | 2,250                 | 71                       | 156                     | 78   | 2,480                      | -                 | 1,624                    |
| MDRE0507   | 50  | 225                          | 400              | 3,210                 | 76                       | 196                     | 98   | 3,740                      | 880               | 1,182                    |
| MDRE0607   | 60  | 294                          | 400              | 3,940                 | 77                       | 228                     | 114  | 3,880                      | 880               | 1,544                    |
| MDRE0757   | 75  | 333                          | 400              | 4,160                 | 78                       | 278                     | 139  | 3,910                      | 880               | 1,544                    |
| MDRE1007   | 100 | 403                          | 400              | 5,280                 | 79                       | 354                     | 177  | 3,910                      | 880               | 1,544                    |

Notes:

- 1- HP is shown with one compressor in reserve per NFPA 99
- 2- dB(A) is shown with one compressor in reserve per NFPA 99
- 3- BTU/Min. and Rated Amps are per compressor unit
- \*Powerex recommends using performance ratings in SCFM (Standard Cubic Feet per Minute) when sizing Medical Air systems.
- \*\* 240 gal. tanks are skid mounted with ATC (Air Treatment Center); 400 gal. and larger tanks are shipped loose.



# Duplex Medical Screw Compressor Enclosure (Water Cooled) and Air Treatment Center Package

Rev. 9/9/13

| DIMENSIONS |        |        |         |        |         |        |        |
|------------|--------|--------|---------|--------|---------|--------|--------|
| MODEL      | DIM. A | DIM. B | DIM. B1 | DIM. C | DIM. C1 | DIM. D | Outlet |
| MDRE0406   | 104"   | 32"    | 67"     | 59"    | 95"     | 24"    | 1-1/2" |
| MDRE0507   | 57"    | 47"    | 70"     | 67"    | 63"     | 24"    | 2"     |
| MDRE0607   | 57"    | 47"    | 70"     | 67"    | 77"     | 24"    | 2"     |
| MDRE0757   | 57"    | 47"    | 70"     | 67"    | 77"     | 24"    | 2"     |
| MDRE1007   | 57"    | 47"    | 70"     | 67"    | 77"     | 24"    | 2"     |

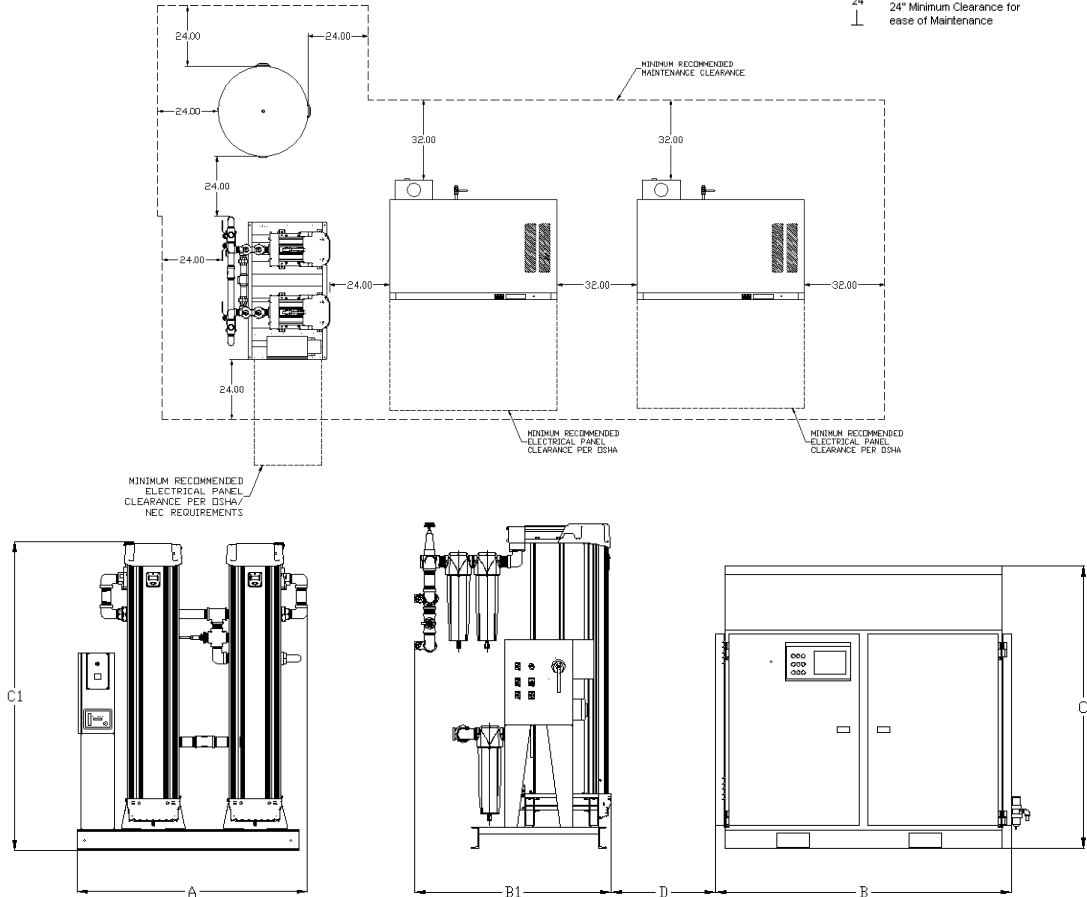
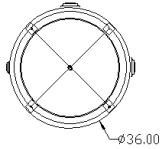
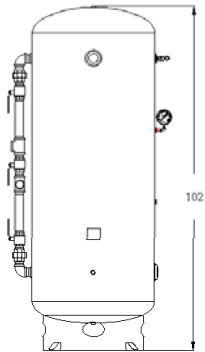
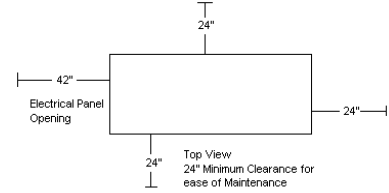

| Duplex Medical Screw Enclosed Air Compressors (Water Cooled) |     |                              |                  |                                |                              |                          |                         |      |                             |                   |                          |
|--|-----|------------------------------|------------------|--------------------------------|------------------------------|--------------------------|-------------------------|------|-----------------------------|-------------------|--------------------------|
| with Air Treatment Center Package                            |     |                              |                  |                                |                              |                          |                         |      |                             |                   |                          |
| MODEL  | HP  | SCFM @ 100 PSIG <sup>1</sup> | Tank Size (Gal.) | BTU/Min. <sup>3</sup> To Water | BTU/Min. <sup>3</sup> To Air | dB(A) LEVEL <sup>2</sup> | RATED AMPS <sup>3</sup> |      | Compress or Unit Wt. (Lbs.) | Tank Wt. (Lbs.)** | Dryer Package Wt. (Lbs.) |
|  |     |                              |                  |                                |                              |                          | 230V                    | 460V |                             |                   |                          |
| MDRE0406   | 40  | 165                          | 240              | 2,030                          | 220                          | 71                       | 148                     | 74   | 2,480                       | -                 | 1,624                    |
| MDRE0507   | 50  | 225                          | 400              | 2,340                          | 240                          | 71                       | 188                     | 94   | 3,740                       | 880               | 1,182                    |
| MDRE0607   | 60  | 294                          | 400              | 2,890                          | 260                          | 71                       | 220                     | 110  | 3,880                       | 880               | 1,544                    |
| MDRE0757   | 75  | 333                          | 400              | 3,320                          | 260                          | 72                       | 272                     | 136  | 3,910                       | 880               | 1,544                    |
| MDRE1007   | 100 | 403                          | 400              | 3,820                          | 280                          | 74                       | 346                     | 173  | 3,910                       | 880               | 1,544                    |

Notes: 1- HP is shown with one compressor in reserve per NFPA 99  
 2- dB(A) is shown with one compressor in reserve per NFPA 99  
 3- BTU/Min. and Rated Amps are per compressor unit  
 \*Powerex recommends using performance ratings in SCFM (Standard Cubic Feet per Minute) when sizing Medical Air systems.  
 \*\* 240 gal. tanks are skid mounted with ATC (Air Treatment Center); 400 gal. and larger tanks are shipped loose.

**Powerex - 150 Production Dr. - Harrison, OH 45030 - Phone: 888-769-7979 - Fax: 513-367-3125**



# Triplex Medical Screw Compressor Enclosure (Air Cooled) and Air Treatment Center Package

Rev. 9/9/13

| DIMENSIONS |        |        |         |        |         |        |        |
|------------|--------|--------|---------|--------|---------|--------|--------|
| MODEL      | DIM. A | DIM. B | DIM. B1 | DIM. C | DIM. C1 | DIM. D | Outlet |
| MTRE0407   | 57"    | 47"    | 67"     | 59"    | 77"     | 24"    | 2"     |
| MTRE0507   | 57"    | 53"    | 70"     | 67"    | 77"     | 24"    | 2"     |
| MTRE0607   | 102"   | 40"    | 70"     | 67"    | 86"     | 24"    | 2-1/2" |
| MTRE0757   | 102"   | 40"    | 70"     | 67"    | 86"     | 24"    | 2-1/2" |
| MTRE1007   | 102"   | 40"    | 70"     | 67"    | 86"     | 24"    | 2-1/2" |

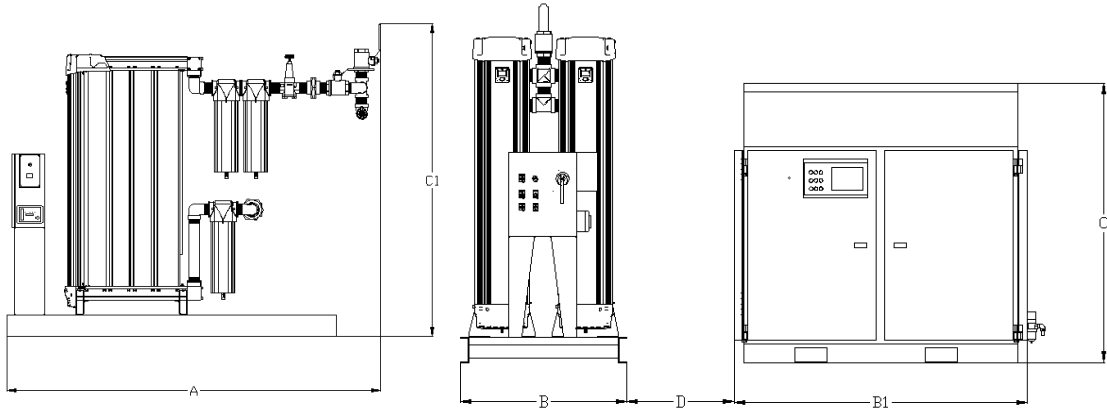
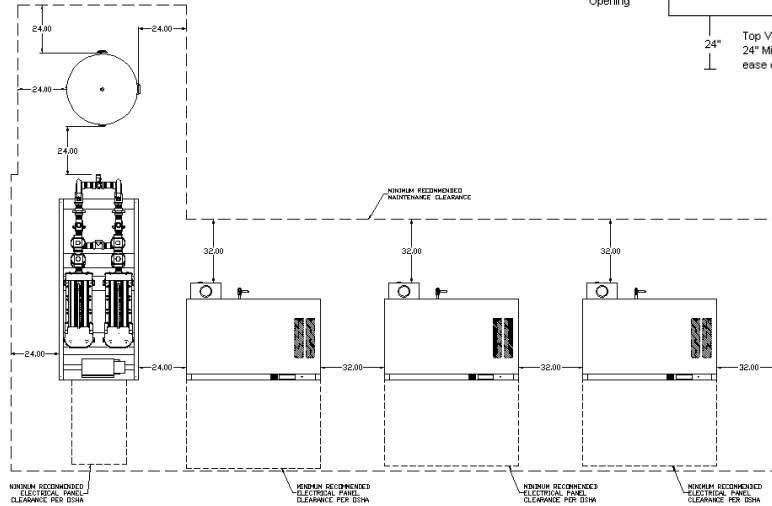
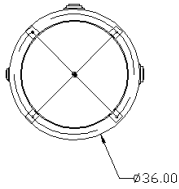
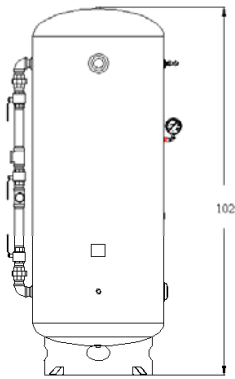
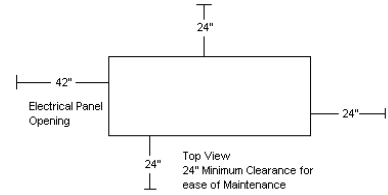

| Triplex Medical Screw Enclosed Air Compressors (Air Cooled) |     |                              |                  |                       |                          |                         |      |                             |                 |                          |  |
|---|-----|------------------------------|------------------|-----------------------|--------------------------|-------------------------|------|-----------------------------|-----------------|--------------------------|--|
| with Air Treatment Center Package                           |     |                              |                  |                       |                          |                         |      |                             |                 |                          |  |
| MODEL   | HP  | SCFM @ 100 PSIG <sup>1</sup> | Tank Size (Gal.) | BTU/Min. <sup>3</sup> | dB(A) LEVEL <sup>2</sup> | RATED AMPS <sup>3</sup> |      | Compress or Unit Wt. (Lbs.) | Tank Wt. (Lbs.) | Dryer Package Wt. (Lbs.) |  |
|   |     |                              |                  |                       |                          | 230V                    | 460V |                             |                 |                          |  |
| MTRE0407  | 40  | 330                          | 400              | 2,250                 | 73                       | 156                     | 78   | 2,480                       | 880             | 1,544                    |  |
| MTRE0507  | 50  | 450                          | 400              | 3,210                 | 78                       | 196                     | 98   | 3,740                       | 880             | 2,026                    |  |
| MTRE0607  | 60  | 588                          | 400              | 3,940                 | 79                       | 228                     | 114  | 3,880                       | 880             | 2,470                    |  |
| MTRE0757  | 75  | 666                          | 400              | 4,160                 | 80                       | 278                     | 139  | 3,910                       | 880             | 2,470                    |  |
| MTRE1007  | 100 | 806                          | 400              | 5,280                 | 81                       | 354                     | 177  | 3,910                       | 880             | 2,470                    |  |

Notes: 1- HP is shown with one compressor in reserve per NFPA 99  
 2- dB(A) is shown with one compressor in reserve per NFPA 99  
 3- BTU/Min. and Rated Amps are per compressor unit  
 \*Powerex recommends using performance ratings in SCFM (Standard Cubic Feet per Minute) when sizing Medical Air systems.

**Powerex - 150 Production Dr. - Harrison, OH 45030 - Phone: 888-769-7979 - Fax: 513-367-3125**



# Triplex Medical Screw Compressor Enclosure (Water Cooled) and Air Treatment Center Package

Rev. 9/9/13

| DIMENSIONS |        |        |         |        |         |        |        |
|------------|--------|--------|---------|--------|---------|--------|--------|
| MODEL      | DIM. A | DIM. B | DIM. B1 | DIM. C | DIM. C1 | DIM. D | Outlet |
| MTRE0407   | 57"    | 47"    | 67"     | 59"    | 77"     | 24"    | 2"     |
| MTRE0507   | 57"    | 53"    | 70"     | 67"    | 77"     | 24"    | 2"     |
| MTRE0607   | 102"   | 40"    | 70"     | 67"    | 86"     | 24"    | 2-1/2" |
| MTRE0757   | 102"   | 40"    | 70"     | 67"    | 86"     | 24"    | 2-1/2" |
| MTRE1007   | 102"   | 40"    | 70"     | 67"    | 86"     | 24"    | 2-1/2" |

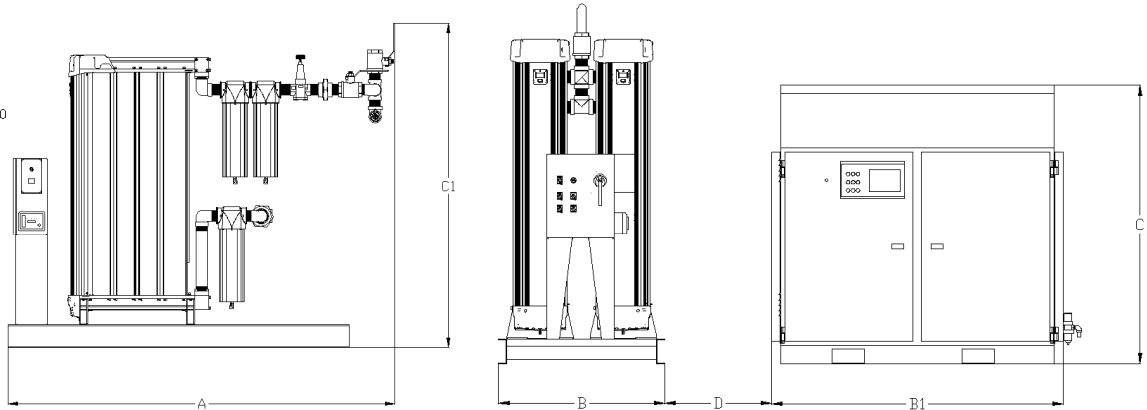
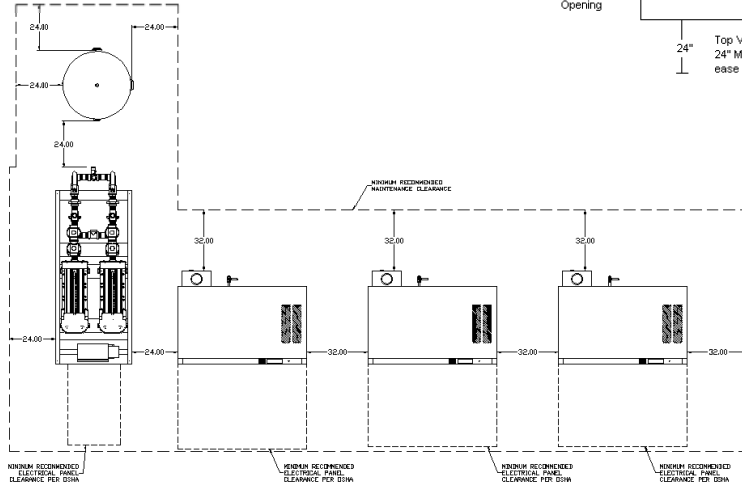
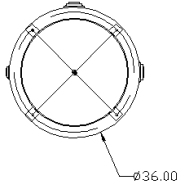
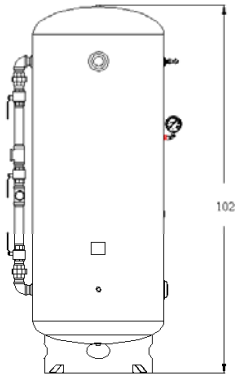
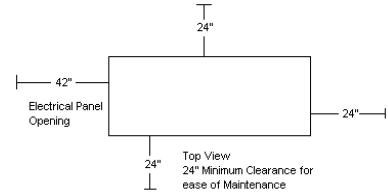

## Triplex Medical Screw Enclosed Air Compressors (Water Cooled) with Air Treatment Center Package

| MODEL    | HP  | SCFM @ 100 PSIG <sup>1</sup> | Tank Size (Gal.) | BTU/Min. <sup>3</sup> To Water | BTU/Min. <sup>3</sup> To Air | dB(A) LEVEL <sup>2</sup> | RATED AMPS <sup>3</sup> |      | Compressor Unit Wt. (Lbs.) | Tank Wt. (Lbs.) | Dryer Package Wt. (Lbs.) |
|----------|-----|------------------------------|------------------|--------------------------------|------------------------------|--------------------------|-------------------------|------|----------------------------|-----------------|--------------------------|
|          |     |                              |                  |                                |                              |                          | 230V                    | 460V |                            |                 |                          |
| MTRE0407 | 40  | 330                          | 400              | 2,030                          | 220                          | 73                       | 148                     | 74   | 2,480                      | 880             | 1,544                    |
| MTRE0507 | 50  | 450                          | 400              | 2,340                          | 240                          | 73                       | 188                     | 94   | 3,740                      | 880             | 2,026                    |
| MTRE0607 | 60  | 588                          | 400              | 2,890                          | 260                          | 73                       | 220                     | 110  | 3,880                      | 880             | 2,470                    |
| MTRE0757 | 75  | 666                          | 400              | 3,320                          | 260                          | 74                       | 272                     | 136  | 3,910                      | 880             | 2,470                    |
| MTRE1007 | 100 | 806                          | 400              | 3,820                          | 280                          | 76                       | 346                     | 173  | 3,910                      | 880             | 2,470                    |

- Notes:
- 1- HP is shown with one compressor in reserve per NFPA 99
  - 2- dB(A) is shown with one compressor in reserve per NFPA 99
  - 3 - BTU/Min. and Rated Amps are per compressor unit
  - \*Powerex recommends using performance ratings in SCFM (Standard Cubic Feet per Minute) when sizing Medical Air systems.